

Owner's Manual

M35 / M65 / M35t / M65t



WARNING

1. Read these instructions - All the safety and operating instructions should be read before this product is operated.
2. Retain these instructions - The safety and operating instructions should be retained for future reference.
3. Heed all warnings - All warnings on the appliance and in the operating instructions should be adhered to.
4. Follow all instructions - All operating and use instructions should be followed.
5. Do not use this apparatus near water - The appliance should not be used near water or moisture - for example, in a wet basement or near a swimming pool, and the like.
6. Clean only with dry cloth.
7. Do not block any ventilation openings. Install in accordance with the manufacture's instructions.
8. Do not install near any heat sources such as radiators, heat registers, stoves, or other apparatus (including amplifiers) that produce heat.
9. Do not defeat the safety purpose of the polarized or grounding plug. A polarized plug has two blades with one wider than the other. A grounding plug has two blades and a third grounding prong. The wide blade or the third prong is provided for your safety. If the provided plug does not fit into your outlet, consult an electrician for replacement of the obsolete outlet.
10. Protect the power cord from being walked on or pinched particularly at the plugs, convenience receptacles, and at the point where they exit from the apparatus.
11. Only use attachments/accessories specified by the manufacturer.
12. Use only with the cart, stand, tripod, bracket, or table specified by the manufacturer, or sold with the apparatus. When a cart or rack is used, use caution when moving the cart/apparatus combination to avoid injury from tip-over.
13. Unplug the apparatus during lightning storms or when unused for long periods of time.
14. Refer all servicing to qualified personnel. Servicing is required when



- the apparatus has been damaged in any way, such as power supply cord or plug is damaged, liquid has been spilled or objects have fallen into the apparatus has been exposed to rain or moisture, does not operate normally, or has been dropped.
15. Please keep the unit in a good ventilation environment.
16. **WARNING:** To reduce the risk of fire or electric shock, do not expose this apparatus to rain or moisture. The apparatus shall not be exposed to dripping or splashing and that no objects filled with liquids, such as vases, shall not be placed on apparatus.
17. **WARNING:** The mains plug or appliance inlet is used as disconnect device, the disconnect device shall remain readily operable.
18. **Power Sources** - This product should be operated only from the type of power source indicated on the rating label. If you are not sure of the type of power supply to your home, consult your product dealer or local power company. For products intended to operate from battery power, or other sources, refer the operating instructions.
19. **Safety Check** - Upon completion of any service or repairs to this product, ask the service technician to perform safety checks to determine that the product is in proper operating condition.
20. Don't touch conductive parts of output terminals to prevent hazardous electrical shock. The external wiring connected to the terminals requires installation by an instructed person or the use of ready-made leads or cords.
21. This equipment is for commercial & professional use only.
22. This product is in compliance with EU WEEE regulations. Disposal of end of life product should not be treated as municipal waste. Please refer to your local regulations for instructions on proper disposal of this product.
23. To prevent hazardous electrical shock, do not touch the conductive parts of the output terminals. The external wiring connected to the terminals requires installation by an qualified technician or the use of ready made leads or cords.
24. Please locate the apparatus at places nearby power socket for quick power disconnection in emergency.



Protective earthing terminal. The apparatus should be connected to a mains socket outlet with a protective earthing connection.



This lightning flash is intended to alert the user to the presence of non-insulated "dangerous voltage" on the output terminals that may be of sufficient magnitude to constitute a risk of electric shock. The external wiring connected to the terminals requires installation by an instructed person or the use of ready-made leads or cords.



CAUTION
RISK OF ELECTRIC SHOCK
DO NOT OPEN



CAUTION: To reduce the risk of electric shock, do not remove any cover. No user-serviceable parts inside. Refer servicing to qualified service personnel only.



The lightning flash with arrowhead symbol within the equilateral triangle is intended to alert the user to the presence of uninsulated "dangerous voltage" within the product's enclosure that may be of sufficient magnitude to constitute a risk of electric shock.



The exclamation point within the equilateral triangle is intended to alert the user to the presence of important operation and maintenance (servicing) instructions in the literature accompanying this appliance.

CAUTION: To prevent electric shock, do not use this polarized plug with an extension cord, receptacle or other outlet unless the blades can be fully inserted to prevent blade exposure.

Table of Contents

Introductions	2
Features	3
Controls	4
Setups	5
Wiring Guide	5
Connections	7
Operations	9
MOH	10
Media module	11
Block Diagram	12
Specifications	13

Introductions



M35(t) / M65(t)

Welcome

Congratulation and thank you for the purchasing M35(t) / M65(t), a multi-function commercial amplifier. These amplifiers are designed to provide a big impact in sound reproduction and to produce the best and highest quality audio at an affordable price. We wish you great enjoyment and satisfaction when using your amplifier, whether you are an installation, or reinforcement engineer.

Unpacking and Installation

Although it is neither complicated to install nor difficult to operate your amplifier, a few minutes of your time is required to read this manual for a properly wired installation and becoming familiar with its features and how to use them. Please take a great care may be needed when moving your set and are required if it ever becomes necessary to return your set for service. Never place the unit near radiator, in front of heating vents, to direct sun light, in excessive humid or dusty location to avoid damages and to guaranty a long reliable use.

Connect your unit with the system components according to the description on the following pages.

Features

The M35(t) / M65(t) mixer amplifiers are comprehensive, all-in-one mixer-amplifier solutions for commercial and industrial applications. These low-cost units provide all necessary features in a simple building-block format.

- * Three microphone and two line inputs with 3 Pin Euro block and RCA jacks.
- * Acceptable wide range(up to 44dB) input level.
- * telephone paging input by Euro block terminal,with LEVEL &DUCKING DEPTH Controls.
- * Two layer priority muting.
- * USB MP3 Player,SD Card,FM Tuner(M35t,M65t only)
- * 35watts(M35) and 65Watts(M65) rated power output.
- * Advanced protection system includes current limiting, over current and thermal protection.
- * Desktop and 19-inches rack mountable type.
- * Two bands tone controls.
- * Low distortion and low noise level.
- * Compact size and lightweight.
- * Ideal commercial and industrial use.

Controls

FRONT PANELS

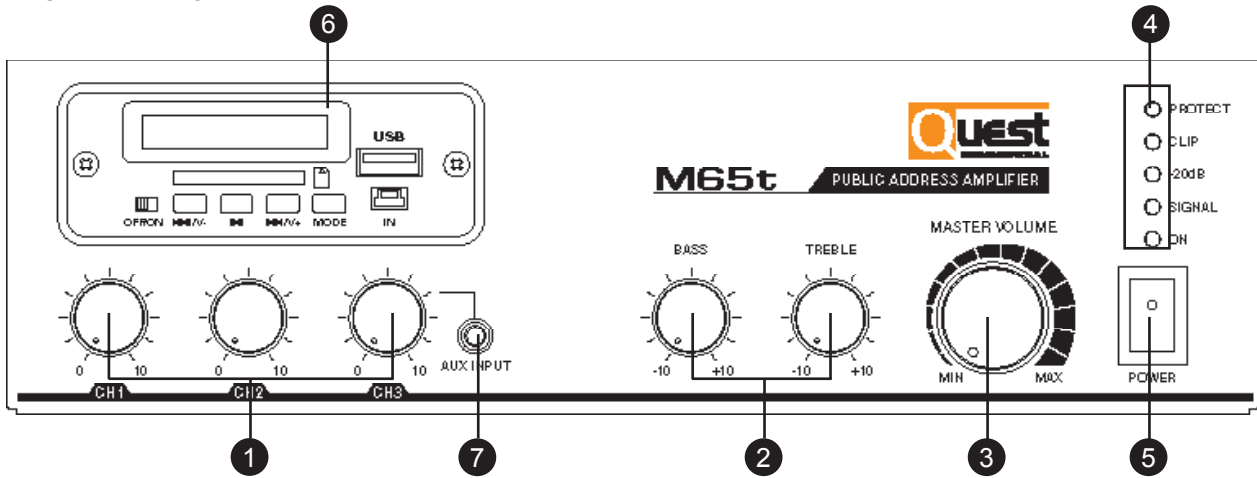

[Figure 1.1 Front panel diagram]

1. Input channel volumes.
2. Two bands tone controls (100Hz/10KHz).
3. Master volume control.
4. Indicators (Protection/Output level/Power).
5. Power switch.
- 6.MP3 Player,SD Card,FM Tuner.
- 7.AUX INPUT

REAR PANELS

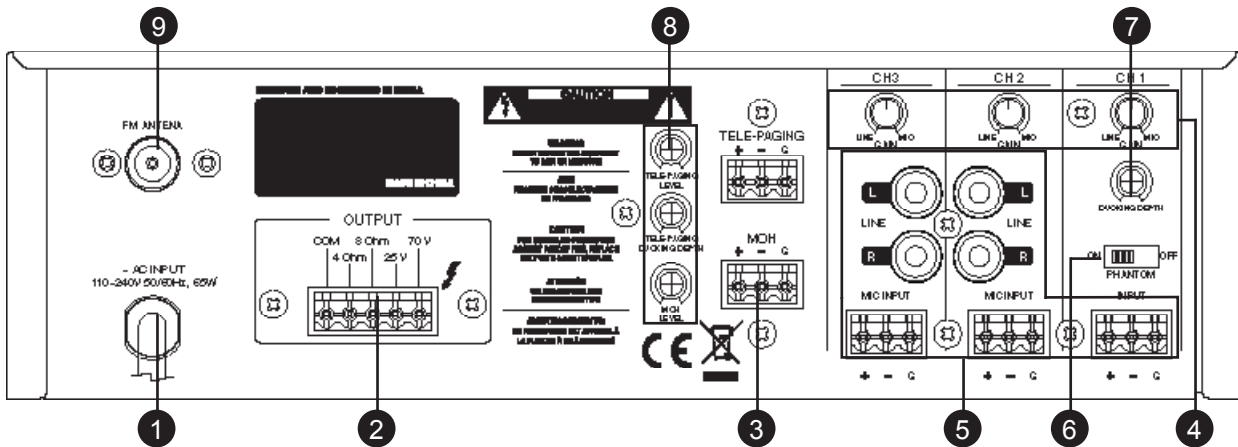

[Figure 1.2 Rear panel diagram]

1. power cable.
2. Speaker outputs connector (COM,4-ohm, 8-ohm 25V,and 70V).
- 3.MOH(Music On Hold) Terminal with LEVEL Control.
4. Gain controls for variable input level.
5. Signal input connectors.
- 6.PHANTOM ON / OFF Switch
- 7.DUCKING DEPTH Control.
- 8.TELE-PAGING Input with LEVEL,DUCKING DEPTH Control.
- 9.FM ANTENNA

Setups

Installation

CAUTION : Before you begin, make sure your mixer-amplifier is disconnected from the power source, with the power switch in the “OFF” position and all level controls turned completely down (counterclockwise). You may stack mixer-amplifiers without using a cabinet or you may place a single mixer-amplifier on a surface with 12-inches (about 30cm) of air space around the unit for convection cooling.

Wiring guide

Choose input wire and connectors

We recommends using pre-built or professionally wired balanced line. 22 to 24 gauge cables.

Figure 2.1 shows connector pin assignments for wiring. The RCA input connections can also be used for unbalanced inputs.

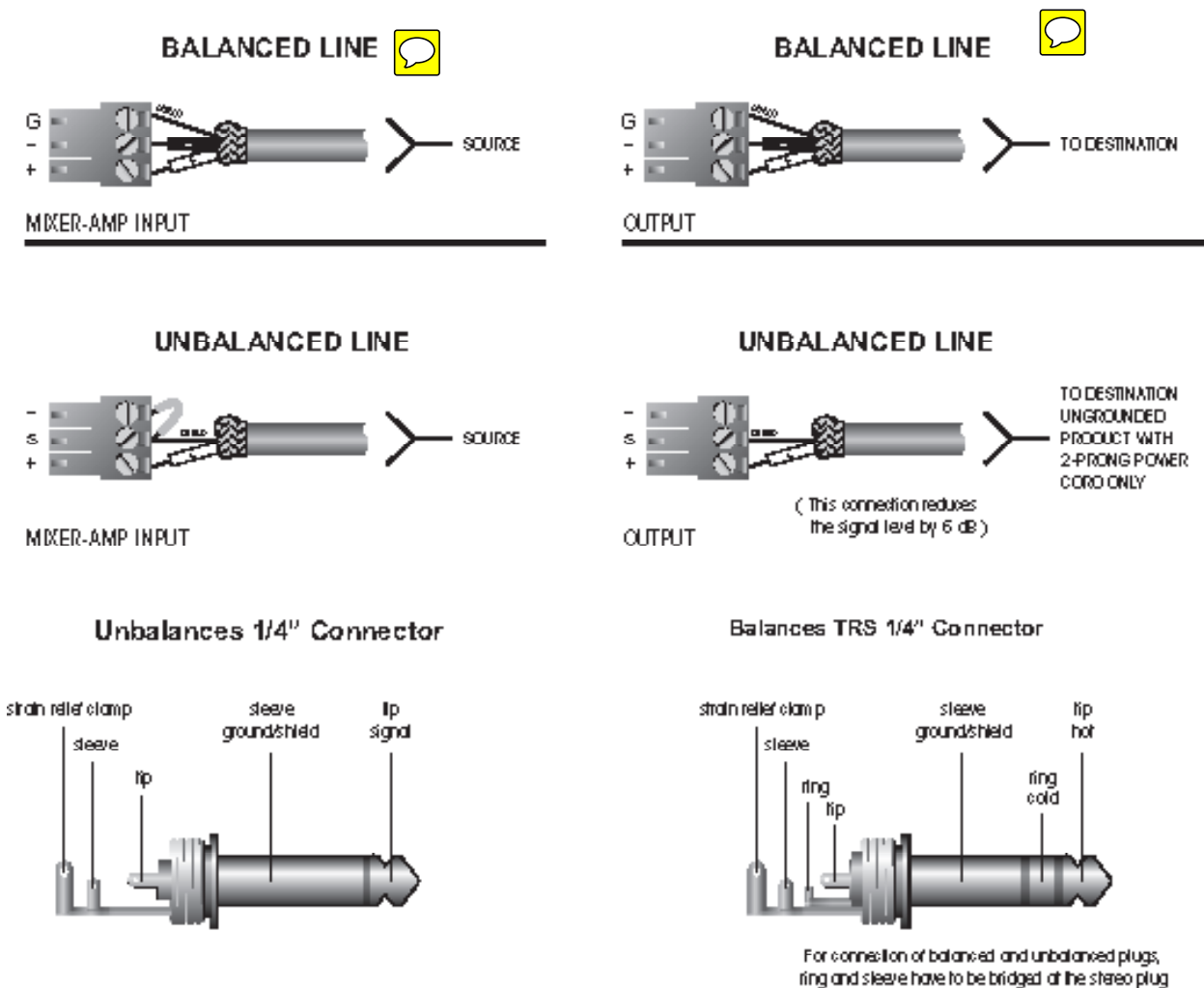

[Figure 2.1 Input wire and connectors]

Choose output wire and connectors

For the amplifier output connectors, We recommends using pre-built or professionally wired, high-quality, and heavy gauge speaker wires. You may use EURO blocks for your output connectors. To prevent the possibility of short-circuits, wrap or otherwise insulate exposed loud-speaker cable connectors

Using the guidelines below, select the appropriate size wire based on the distance from amplifier to speaker. The wire sizes apply to the 4-ohm tap.

Distance	Wire Size
Up to 25 ft.	16 AWG
26~40 ft.	14 AWG
41~60 ft.	12AWG
61~100 ft.	10AWG
101ft~150 ft.	8AWG
151~200 ft.	6AWG

NOTE : Custom wiring should only be performed by qualified personnel. Class 2 wiring is required.

CAUTION : Never use shielded cable for output power wiring

Connections

Choose input wire and connectors

INPUT : Connect microphones or balanced line-level sources to mixer-amplifier balanced inputs.

Set Gain volume accordingly. Connect unbalanced line-level signals to RCA input connectors.

OUTPUT : Maintain proper polarity on output connectors.

For each output channel, connect the output EURO block terminals to the loudspeaker loads.

Use terminals marked COM and 4Ω / 8Ω for a loudspeaker load, or use terminals marked 25V, 70V, COM for constant-voltage speaker loads.

Connect the COM terminal to speaker negative(-) lead; connect one of the other terminals to speaker positive(+) lead.

The impedance and output voltage are same as following Table 2.1

M35(t)	4Ω / 11.8V	8Ω / 16.7V	140Ω / 70V	17.8Ω / 25V
M65(t)	4Ω / 16V	8Ω / 22.8V	75Ω / 70V	9.6Ω / 25V

[Table 2.1 Output voltage and impedance]

NOTE : Impedances indicated in the table 2.1 represent the total speaker system impedances. Speaker connection is shown in Figure 2.2

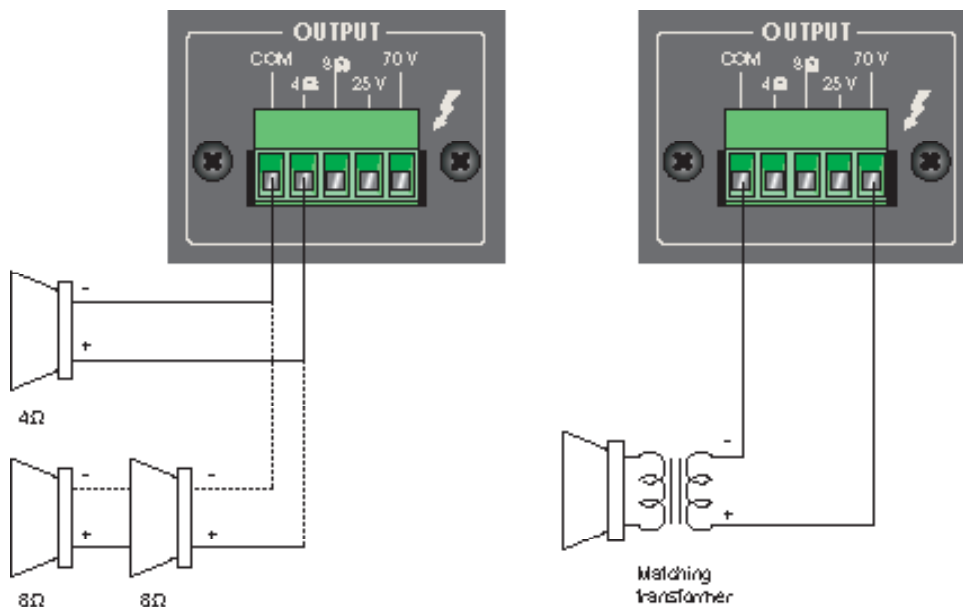

[Figure 2.2 How to connect speakers]

CAUTION : Never use both the Low-Z(4Ω / 8Ω)and Hi-Z(25V, 70V) terminals at the same time

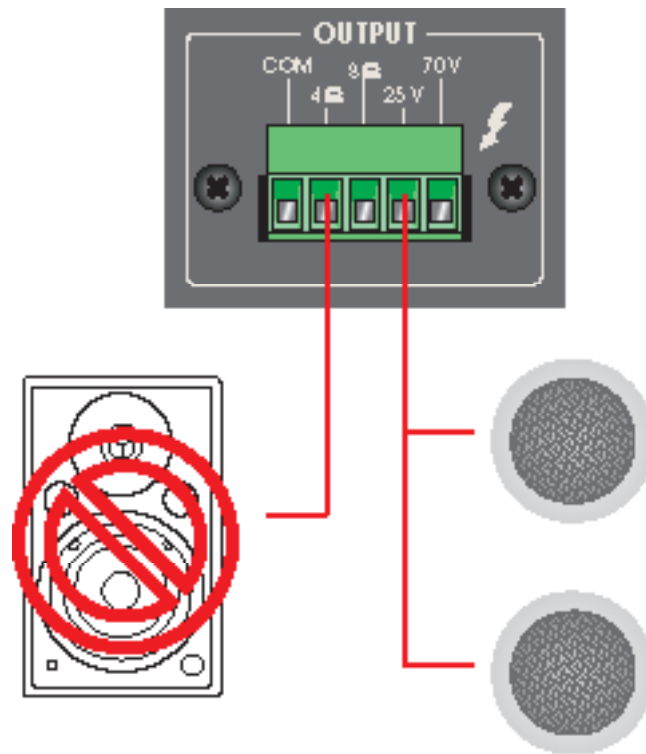

[Figure 2.3 Wrong connection]

Operations

Telephone paging

Connect mixer-amplifier TELE-PAGING connector to telephone interface unit/PBX like telephone pager.

You can announce by telephone after dial up to telephone interface unit/PBX.

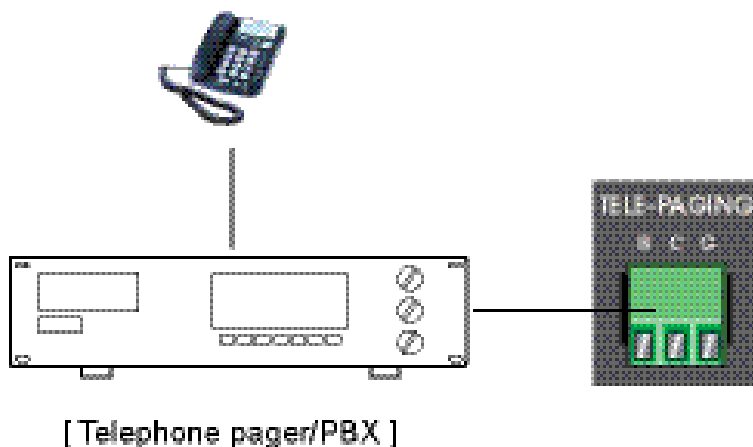

[Figure 3.1 Telephone paging connection]

Signal input gain control

M series mixer-amplifier can accept variable and wide range input signal with trim pot.

Adjusts the trim pot in a range of 44dB to accept variable external equipments.

Figure 3.2 shows detail input sensitivities.

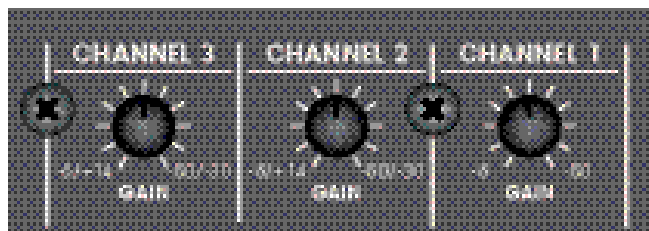

[Figure 3.2 Acceptable input sensitivity per each channels]

Priority Control

M series mixer-amplifier has two layer priority mute function. When higher level source is activated, other input signals are muted automatically except same priority level source.

CH2,CH3,AUX >CH1 > Telephone Paging.

MOH

For 2-Channel Broadcast below Example can be Performed When the Unit is used in conjunction with the Optional M35(t) or M65(t).

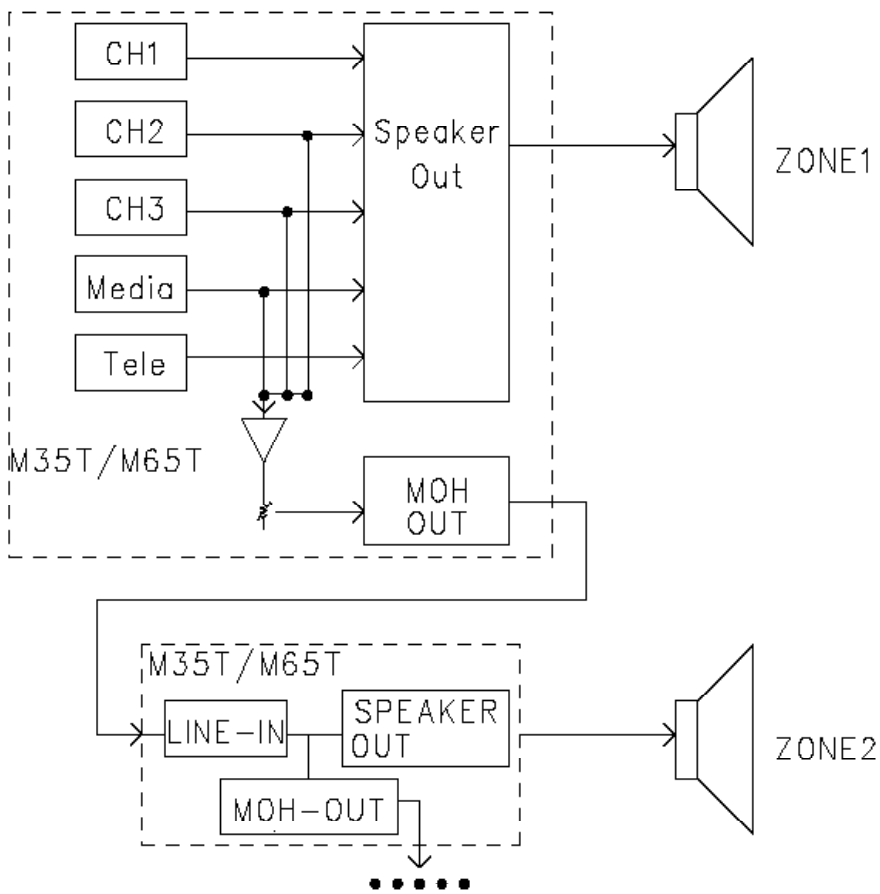

Media module _ M35t,M65t Only

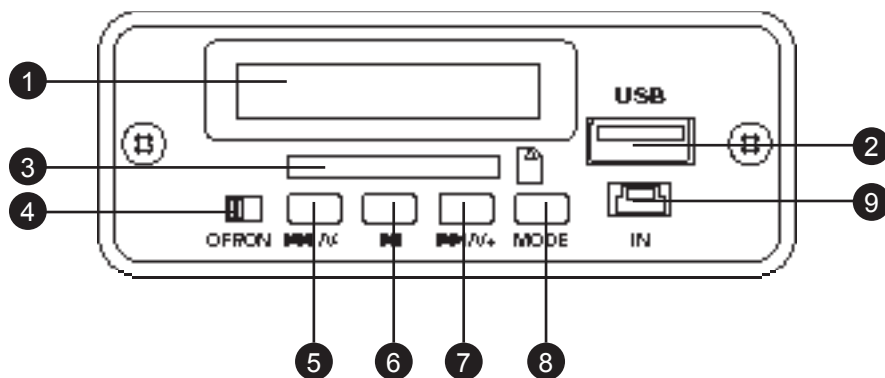
**1.Display****2.USB Connector.**

You can insert USB disk then play MP3 automatically.

3.SD Card Slot.

You can insert SD card then play MP3 automatically.

4.ON / OFF SWITCH**5.PREV / VOL -.**

Long pressing for volume down.

In USB mode,short pressing for previous song.

In tuner mode,short pressing for previons channel.

6.PLAY / PAUSE.

In USB mode,short pressing for play / pause.

In tuner mode,long pressing for search channel and save.

7.NEXT / VOL +.

Long pressing for volume up.

In USB mode,short pressing for next song.

In tuner mode,short pressing for next channel.

8.MODE SWITCH.**9.LINE INPUT**

Block Diagram

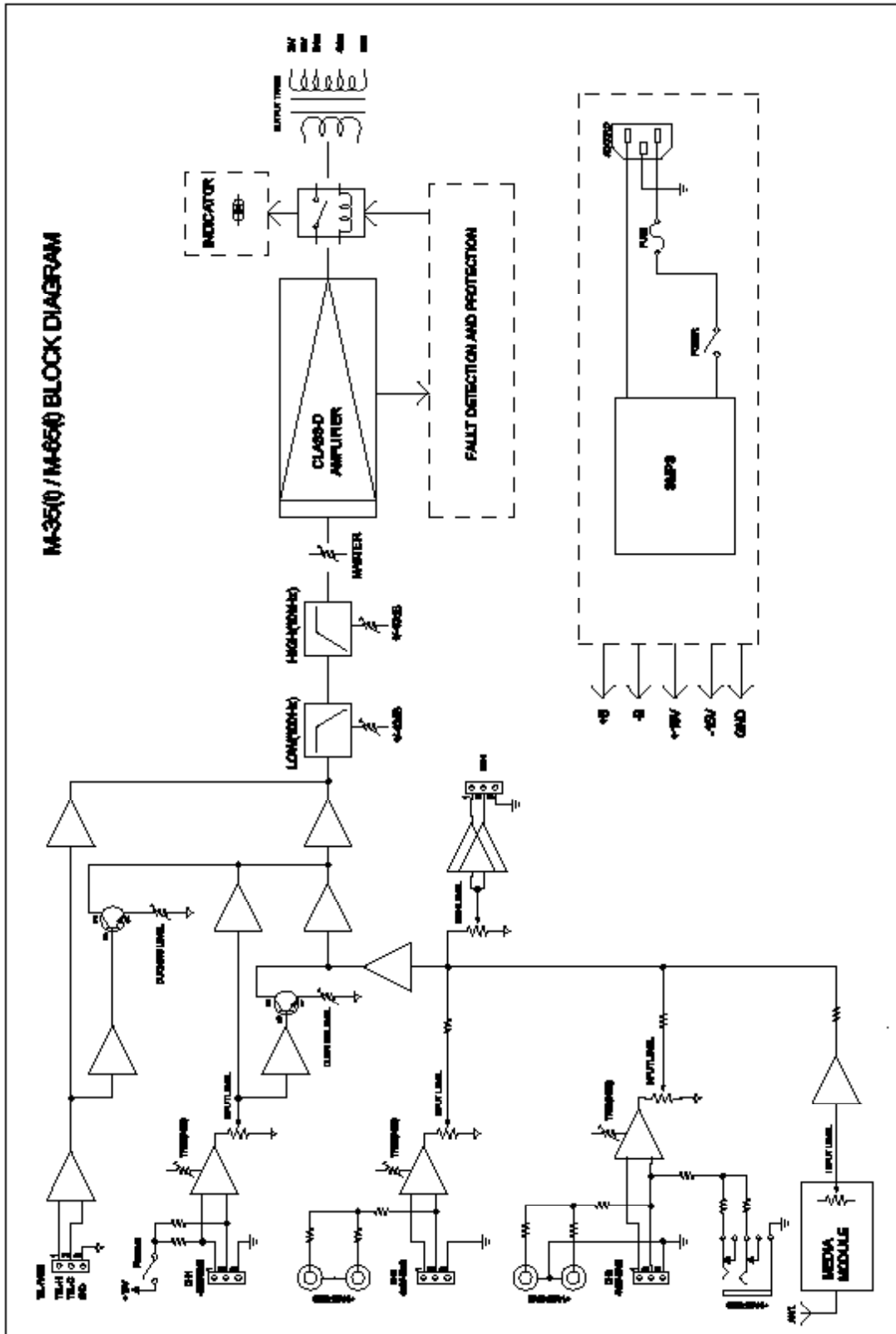

Specifications

Performance		
	M35(t)	M65(t)
Input Sensitivity for full output at maximum gain		
Balanced Microphone Channels	-50dB ± 3dB	
Unbalanced AUX Channels	-30dB ± 3dB	
Tele-Paging	-21dB ± 3dB	
Frequency Response		
at 1watt from speaker out tap, 80Hz ~18kHz	+1.5/-3dB	
Tone Controls		
100Hz,10kHz	±12dB±3dB	
Signal to Noise Ratio at rated power output	Less than 90dB	
Crosstalk at all control maximum	-70dB at 1kHz	
Rated Output Power at THD 0.5%	35 Watts	65 Watts
Total Harmonic Distortion(THD) at 1kHz rated power	Less than 0.5%	
Power Band Width at 1kHz from speaker out tap	80Hz~18kHz with less than 0.5% THD	
DC Output Offset	Less than ±3mV	
Operating Temperature/Humidity at non-condensing	0°~40°C at 95% humidity	
Output Voltage and Impedance		
4Ω	11.8V	16V
8Ω	16.7Ω	22.8Ω
25V	17.8Ω	9.6Ω
70V	140Ω	75Ω
Construction		
Cooling	Convection Cooled	
Dimensions (Width/Height/Depth)	270 mm X 76 mm X 230 mm	
Net Weight	3.59 kg	3.21 kg

Necessary modifications are carried out without notice

